

CHANDLER FTLH – EXW FERTILIZER AND LIME SPREADER



- Wider Spread Patterns
90' Fertilizer
60' Lime
- Belt-Over Bar Chain or
Mesh Type Chain
- Dished Type Spinners
Designed for Maximum
Coverage on Spread
Pattern
- Designed to Fit Almost
Any Floater Chassis
- Tandem Pump System
with 50-Gallon
Hydraulic Oil Tank

**New Cleaner Design, Wider Spread Patterns
With The Same Dependability**

The new FTLH-EXW has the same dependability, accuracy and reliability that Chandler Spreaders have been known for over the past thirty-eight years with a new cleaner design and wider spread patterns. Our *field proven dished type spinners with a new four-blade system* give the Chandler FTHL-EXW an oval pattern that has been the desirable pattern throughout the industry for many years. All Chandler Spreaders are available with Mid-Tech or Raven Control systems.

Chandler FTLH – EXW Hopper

Specifications

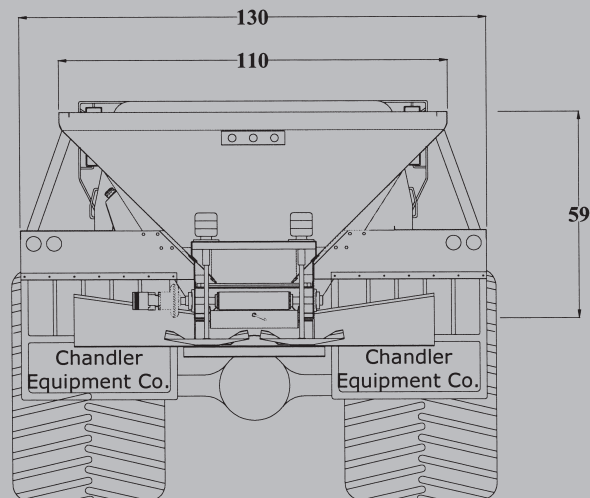
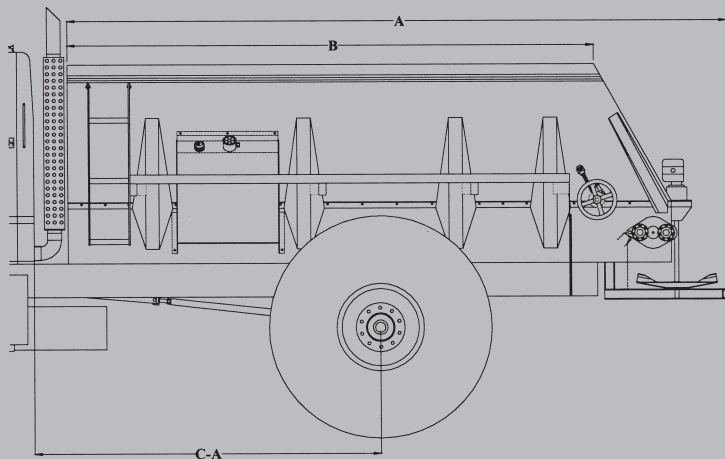

	11' Unit	12' Unit	13' Unit
A – Overall Length	195 1/2"	183 1/2"	195 1/2"
B – Inside Hopper	132"	144"	156"
Cab to Center of Axle	96"	102"	108"

	11' Unit	12' Unit	13' Unit
Hopper Capacity (Struck Level)	257 Cu. Ft.	280 Cu. Ft.	303 Cu. Ft.

Payload (struck level) (@ 65# Material)	16,702 Lbs.	18,220 Lbs.	19,695 Lbs.
--	-------------	-------------	-------------

	11' Unit	12' Unit	13' Unit
Hopper Capacity (Heaped and Tarped)	287 Cu. Ft.	310 Cu. Ft.	340 Cu. Ft.

Payload (Heaped) (@ 65# Material)	18,655 Lbs.	20,150 Lbs.	22,110 Lbs.
--------------------------------------	-------------	-------------	-------------

Spread Patterns:

Fertilizer up to 90'

Lime up to 60'

All Products and Specifications subject to change without notice. Drawing shown with 45 degree slope sides and 24" Belt Over Bar Chain.

Hopper Construction:

Available in three types of material: Mild Steel, 409 Stainless Steel, 304 Stainless Steel

Conveyor Specifications:

Available in three types: 24" – 1" x 1" Mesh Type-304 Stainless Steel, Bar Type Chain and Belt Over – Bar Type Chain

Spinner Specifications:

Four blade configuration spinners and a specially designed flow divider for wide swath applications. (60' Lime – 90' Fertilizer)

High Pressure, Double Bearing spinner motors mounted overhead keeps motors out of fertilizer and other contaminants for longer life.

