

Chandler Equipment Co.

P.O. Box 2533, 1111 East Ridge Road

Gainesville, Georgia 30503

1-800-243-3319, 770-535-1265 fax

Pull Type Poultry Litter Spreader

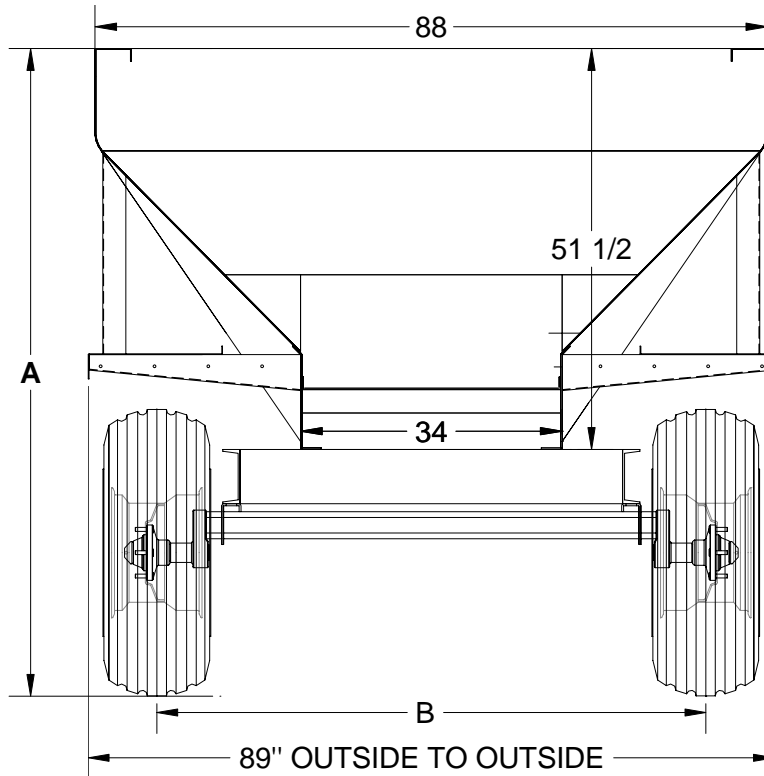

Standard 45-Degree Slope Sides

	Tire Size			
	12.5L x 15	14L x 16.1	16.5L x 16.1	19L x 16.1
A) Total Height	82 3/4"	85 1/2"	86 3/4"	87 3/4"
B) Track	72"	72"	78"	79"

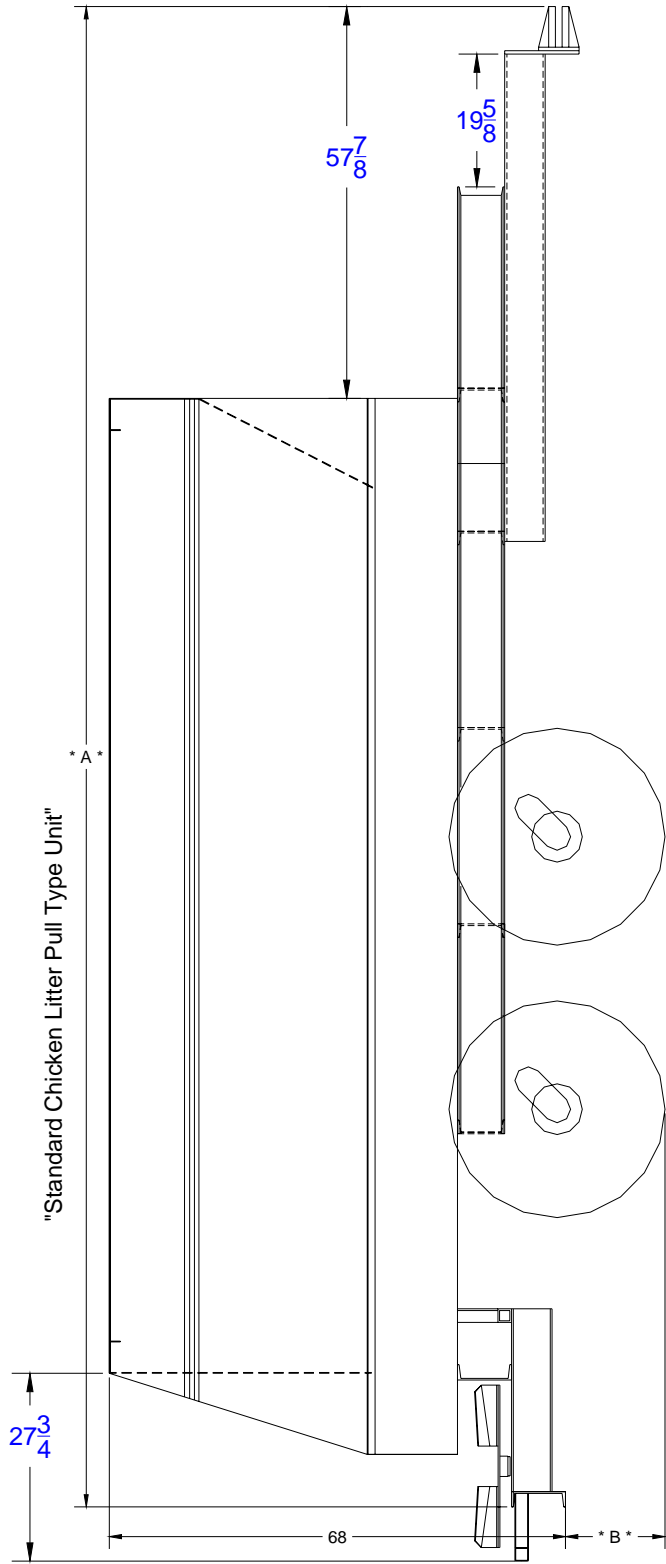

Add 78" to Designated Body Length to get Length "A."

TIRES
 12.5L 14L 16.5L 19L
 B 14.75" 17.25" 18.75" 19.75"

Add Specified Length Above in Accordance with Tire Size to get Length "B."

1) **Hopper Specifications:**

A) **Hopper Construction:**

- 1) **Rails: 7 gauge**
- 2) **Floor: 7 gauge**
- 3) **Sides & Ends: 10 gauge**
- 4) **Gussets & Catwalks: 12 gauge**

B) **Hopper Dimensions: (see attached drawing)**

- 1) **Hopper Width:**
 - a. **88" (standard 45 degree slope sides)**
 - b. **74" (52 degree slope sides)**
 - c. **72" (60 degree slope sides)**
- 2) **Height: (from frame)**
 - a. **51 1/2" (standard 45 degree slope sides)**
 - b. **52" (52 degree slope sides)**
 - c. **51 3/4" (60 degree slope sides)**
- 3) **Length: Sizes available from 10' – 24'**
- 4) **Gate Opening: 14 1/2" High x 33 1/2" wide**

C) **Hopper Capacity:**

- 1) **45 Degree Slope Sides: 19.7 Cubic Feet Per Running Foot (struck level)**
- 2) **52 Degree Slope Sides: 17.8 Cubic Feet Per Running Foot (struck level)**
- 3) **60 Degree Slope Sides: 16.16 Cubic Feet Per Running Foot (struck level)**

2) **Conveyor Drive:**

A) **Mechanical (PTO)**

- 1) **Conveyor Gear Case: Oskaloosa 50:1 w/ 2" cross shaft**
- 2) **Conveyor Chain: Drives D-667x Pintle Type Chain with 3/8" x 1 1/4" bars on 11 1/4" spacing.**
- 3) **Drive Sprockets: 8 Tooth – 3/4" thick Plate**
- 4) **Roller Shafts: Rear 2" C1018 Cold Roll, Front 1 1/2" C1018 Cold Roll**

B) **Hydraulic Drive:**

- 1) **Conveyor Gear Case:**
 - a. **Rawson 6:1 Reduction with single motor (for units 16' and under)**
 - b. **Rawson 6:1 Reduction with tandem motors (for units over 16' in length)**
- 2) **Conveyor Motors:**
 - a. **Parker/Ross MB180102AAAA (on single)**
 - b. **Parker/Ross MB120102AAAA (on tandem)**

- 3) **Conveyor Chain: Drives D-667x Pintle Type Chain with 3/8" x 1 1/4" bars on 11 1/4" spacing.**
- 4) **Drive Sprockets: 8 Tooth – 3/4" thick Plate**
- 5) **Roller Shafts: Rear 2" C1018 Cold Roll, Front 1 1/2" C1018 Cold Roll**

3) **Drive Shaft Assembly:**

A) **Mechanical (PTO)**

- 1) **PTO Shaft: Bondoli & Pavesi # 4**
- 2) **Drive Shaft: 1 1/4" C1018 Cold Roll**
- 3) **Bearings: Standard UCP-207-20 Pillow Block**
- 4) **U-Joints: Buyers H-7 Series**
- 5) **Belts and Pulleys: Heavy QD Bushing Type Pulley with B Series Belts**

B) **Hydraulic Drive:**

- 1) **Pump: (three options on standard unit)**
 - a. **Prince PTO Pump – 22.5 GPM @ 540 RPM**
 - b. **Prince PTO Pump – 22.5 GPM @ 1000 RPM**
 - c. **Prince PTO Pump – 40 GPM @ 1000 RPM (recommended for units over 22' in length)**
 - d. **Tandem Pump System – 540 or 1000 RPM set up**
- 2) **PTO Shaft: (tandem pump)**
 - a. **Bondoli & Pavesi # 4**
 - b. **U-Joints: Buyers H-12 Series**
 - c. **Bearing: Standard UCF-207-20 Flange Bearing**
- 3) **Valves:**
 - a. **Spinners: Brand FCR – 51 – 3/4"**
 - b. **Drag Chain: Brand FCR – 51 – 3/4"**
- 4) **Spinner Motors:**
 - a. **Parker / Commercial Intertech M-30 (standard)**
 - b. **Parker / Commercial Intertech M-25 (optional)**

4) Frame Assembly:

A) Axles:

- 1) 6,500 # Henschen Torsion Axles with 35-6 hubs (standard on units 16' and under)**
- 2) 10,000 # Henschen Torsion Axles with 60-8 hubs (standard on units 18' and above)**

B) Tires:

- 1) 12.5L x 15 - 8 Ply Implement Tires (standard on units 16' and under with 6,500 # Axles)**
- 2) 14L x 16.1 - 8 Ply Implement Tires (optional on units 16' and under with 6,500 # Axles)**
- 3) 16.5L x 16.1 - 10 Ply Implement Tires (standard on units 18' and above with 10,000 # Axles)**
- 4) 19L x 16.1 - 10 Ply Implement Tires (optional on units 18' and above with 10,000 # Axles)**

C) Frame:

- 1) Main Frame:
 - a. 7" x 9.8 Channel (units 16' and under)**
 - b. 8" x 11.5 Channel (units 18 and above)****
- 2) Frame Tongue: 4" x 6" x 5/16" Tube**
- 3) Hitch: Heavy Duty Adjustable Clevis Type**
- 4) Jack: Bulldog 7,000 # Drop Foot**