

Chandler SDT – MH 24 Semi-Trailer Specifications

Trailer

Length: 40'

Width: 8'

Main Frame: 14 Inch @ 43 # w/ 6" Bridge from neck to suspension

King Pin Setting: 18"

King Pin Height: 49"

Suspension: Hutch 9700 – 25,000 #

Axles: Two (2) 71 1/2" Track @ 25,000 Capacity Each

Hubs: Budd 10 Hole

Wheels: 22.5 Budd Steel Wheels

Tires: 255/70R 22.5 (11R22.5) Radial Tires

Brakes: Spring Brake on Air

Landing Gear: 2 Speed Crank Down

Bumper: DOT approved with Mud flaps

Lights: Sealed Beams

Trailer Weight: 8,500 #

Hopper

Length: 24'

Width: 96"

Number of Hoppers: 3

Compartments: 6

Capacity: 24 – Tons (based on 65# per cubic ft. material)

Empty Weight: 8,000 # (hopper only)

Auger and Tube Assembly

Auger Tube: 10" 304 Stainless Steel

Auger: 9 1/2" – 304 Stainless Steel Flighting and Pipe

Engine

Type: John Deere four (4) Cylinder Diesel

Horse Power: 66

Engine Weight: 620 # (with enclosure)

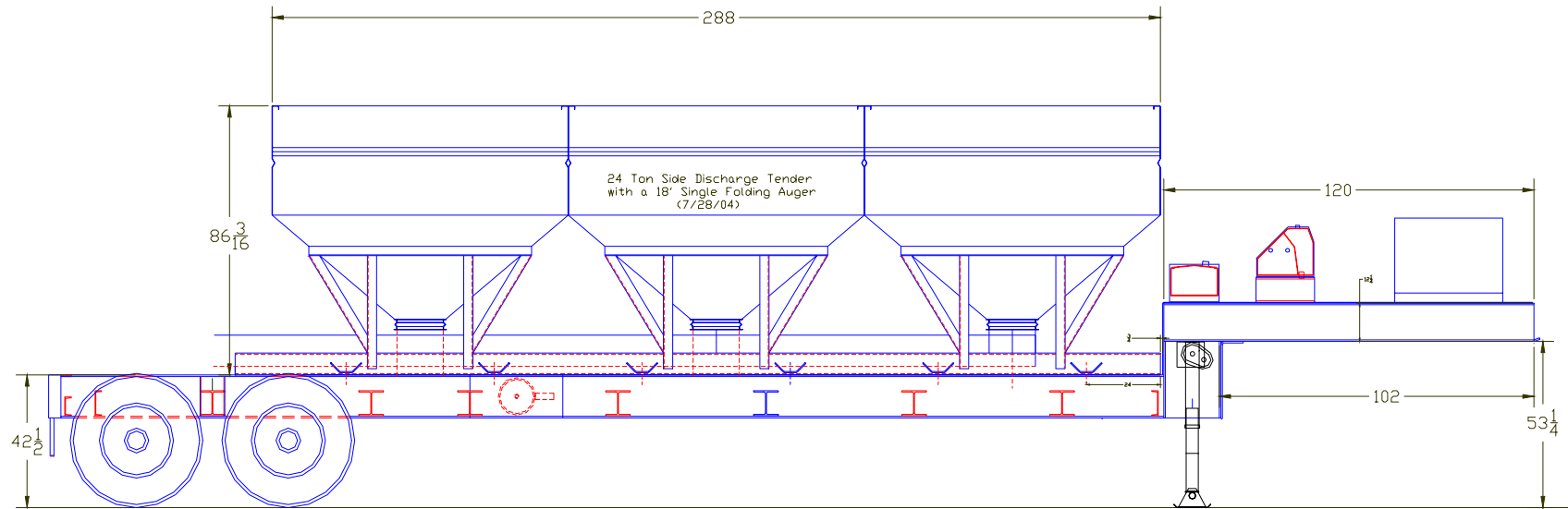

**Chandler SDT – MH 24 Ton
Semi-Trailer Tender Empty Weight 17,940 #**

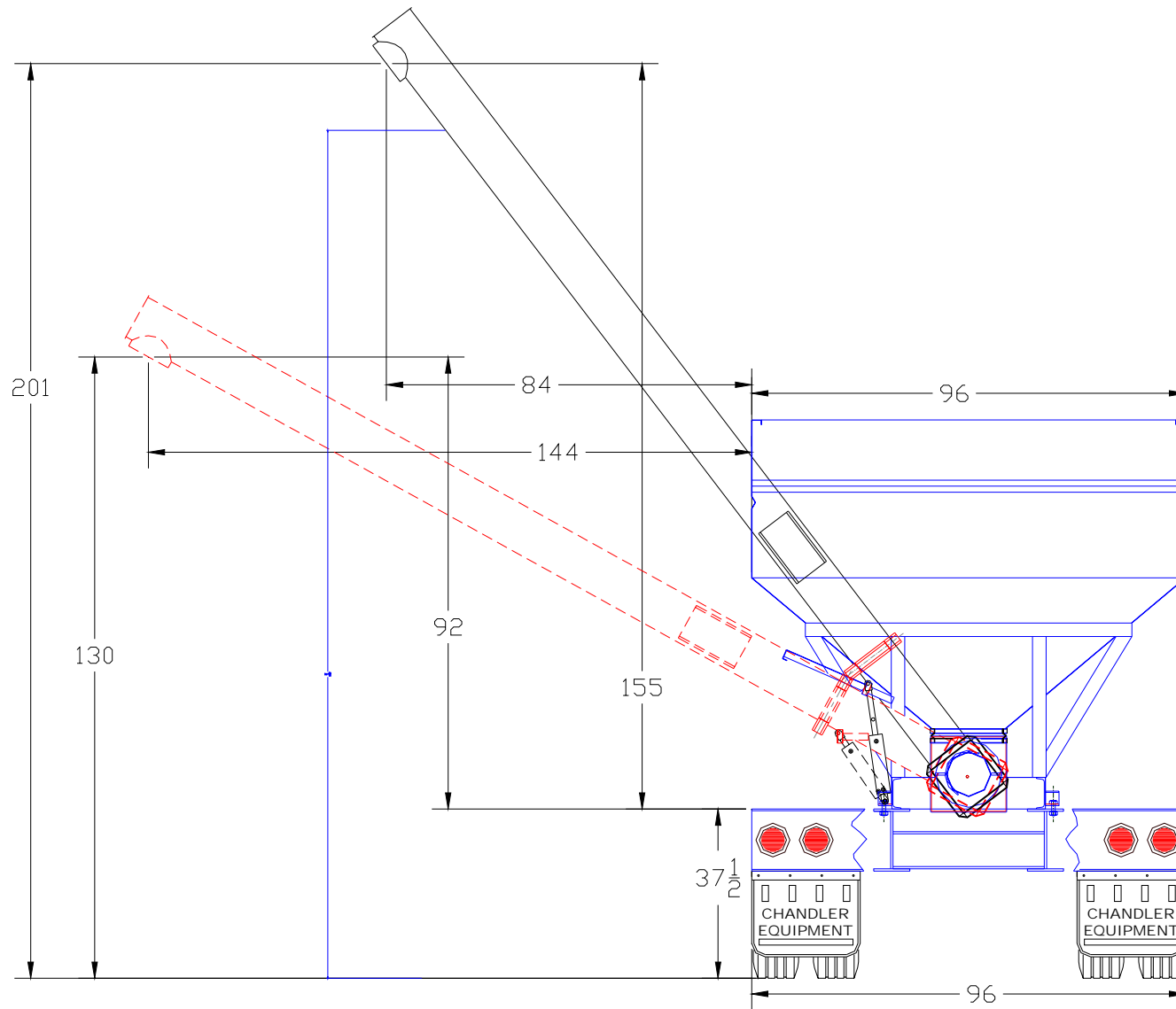

Chandler SDT – MH 24 Ton Discharge Height